



Battery and Power Pack for Trucks and Trailers that operate electrical and hydraulic equipment.



With unique charging that fits all trucks regardless of fuel.



P-LIGHT are...



...Battery and Power Pack that operate electric, pneumatic and hydraulic functions on heavy vehicles. With a unique recharging that fits all trucks regardless of fuel.

Reduces the load..



...from the truck's system when the trailer is connected. It then acts as an accumulator that balances the output from the truck.

Operates functions...



- Parking lights
- Strobe lights
- Work lights
- Heating systems
- Ramps



- Trailer cover
- Tail lifts
- Double floor
- Axle steering and valves on trailers

P-LIGHT operates the most common electrical and hydraulic functions on trailers

The benefits are...



...P-LIGHT makes the trailer independent of the truck and all functions can be run when the trailer is disconnected. As soon as the trailer is connected to the truck, the batteries are intelligently recharged.

Can be operated manually or by remote control with P-LIGHT Radio.

Climate smart...



...and financial. Less idling, saves fuel. Long service life provides good economy and increases operational reliability. User-friendly and provides a good working environment. Minimizes emissions as it makes the trailer's functions independent of the truck.

Capacity



Charging is temperature-controlled while driving with P-LIGHT's unique control unit. From 5A up to 30A. P-LIGHT has a battery capacity from 18Ah up to 200Ah, which enables a wide range of applications.

P-LIGHT Midi



Midi is used when only parking lights are to be operated.

Art No.	Article
PL1177	P-LIGHT Midi

P-LIGHT Maxi/Maxi XL



Maxi is used when parking lights are to be operated together with strobe and work lights together with pneumatic valves for drawbars, flat lock, or other electrical equipment.

Maxi XL is also equipped with a power take-off up to 100A or a relay up to 50A, fits together with hydraulic and electrical equipment such as power packs, heaters and vibrators.

Art No.	Article
PL1407	P-LIGHT Maxi
PL14071-XL-STD	P-LIGHT Maxi XL 10A, Solenoid >100A
PL14071-XL-STD-R	P-LIGHT Maxi XL 10A, Relay >50A
PL14072-XL-STD	P-LIGHT Maxi XL 20A, Solenoid >100A

P-LIGHT Maxi XL HyCover



Maxi XL HyCover operates Ängsgården's HyCover together with parking lights, flash/work lights and pneumatic valves for tie rods, flat lock, or other electrical equipment. Supplied together with 8- or 10-button radio control.

Art No.	Article
PL14071-XL-HC02R8	P-LIGHT Maxi XL 10A HyCover 2xSol. Rev. R8/11
PL14071-XL-HC02R10	P-LIGHT Maxi XL 10A HyCover 2xSol. Rev. R10/19

P-LIGHT Magnum

P-LIGHT Magnum is the best alternative to drive electrical and hydraulic equipment on trailers that require large power outputs. It is available with charging from 10A up to 30A and batteries from 120 to 200Ah.

It has a main switch, power fuse and control switch and can be equipped with a solenoid or relay for operation of e.g. rear end lifts, power packs, heaters and biplanes.

See function overview on page 6

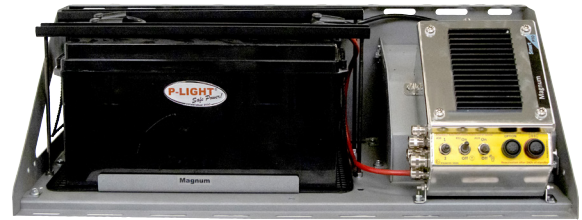

P-LIGHT Magnum 880



P-LIGHT Magnum Frame 435/567



P-LIGHT Magnum Split

Art No.	Article
PL1715081-STD	P-LIGHT Magnum 880 10A/150Ah
PL1715082-STD	P-LIGHT Magnum 880 20A/150Ah
PL1720082-STD	P-LIGHT Magnum 880 20A/200Ah
PL1720083-STD	P-LIGHT Magnum 880 30A/200Ah
PL1712501-1	P-LIGHT Magnum Frame 435 10A/120Ah
PL1715501-1	P-LIGHT Magnum Frame 435 10A/150Ah
PL1715502-1	P-LIGHT Magnum Frame 435 20A/150Ah
PL1715502-1-R	P-LIGHT Magnum Frame 435 20A/150Ah Relay 50A
PL1720602-1	P-LIGHT Magnum Frame 567 20A/200Ah
PL17150S1-STD	P-LIGHT Magnum Split 10A/150Ah
PL17150S2-STD	P-LIGHT Magnum Split 20A/150Ah
PL17200S3-STD	P-LIGHT Magnum Split 30A/200Ah

P-LIGHT Magnum Frame mounting directly on the frame. Frame bracket will be added, there are various different frame brackets for P-LIGHT Magnum Frame.

P-LIGHT Magnum 880 mounting in toolbox. Dimensions: 100x50x50 cm.

P-LIGHT Magnum Split mounting in a toolbox or similar. Electronics box and batteries are delivered separately.

P-LIGHT Maxi XL Hydro Comp



With P-LIGHT Maxi XL Hydro Comp, you operate hydraulic equipment, a total of 5-10 operations/day and 30-60 sec/operation together with parking lights, strobe/work lights and pneumatic valves for drawbars, flat lock, or other electrical equipment.

Can be equipped with up to 3 hydraulic together with pneumatic valves and delivered with 3-, 8- or 10-button radio control.

See function overview on page 6.

Art No.	Article
PL14071-XLH2-PT	P-LIGHT Maxi XL 10A Hydro Comp - P&T
PL14071-XLH2-1VALVE	P-LIGHT Maxi XL 10A Hydro Comp - 1 Valve
PL14071-XLH2-2VALVE	P-LIGHT Maxi XL 10A Hydro Comp - 2 Valves
PL14071-XLH2-3VALVE	P-LIGHT Maxi XL 10A Hydro Comp - 3 Valves

P-LIGHT Maxi XL 1-Axle Steering

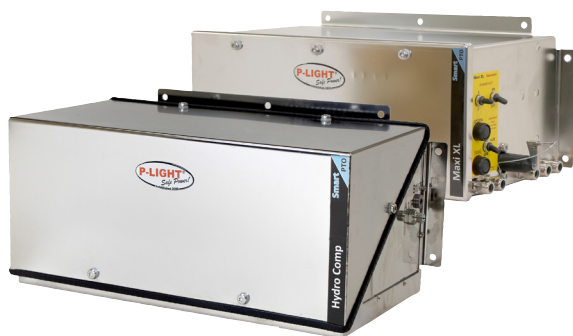

With P-LIGHT Maxi XL Hydro Comp, you operate 1-axle steering and pneumatic valves for axle locking (co-tracking and steerable axles), together with parking lights, strobe/work lights and pneumatic valves for drawbars, flat lock, or other electrical equipment.

Supplied with installed P-LIGHT Radio which makes maneuvering very easy.

See also function overview on page 6.

Art.nr	Article
PL14071-XLH2-A1P1R8	P-LIGHT Maxi XL 10A Hydro Comp A1P1R8
PL14071-XLH2-A1P2R8	P-LIGHT Maxi XL 10A Hydro Comp A1P2R8

P-LIGHT Hydro

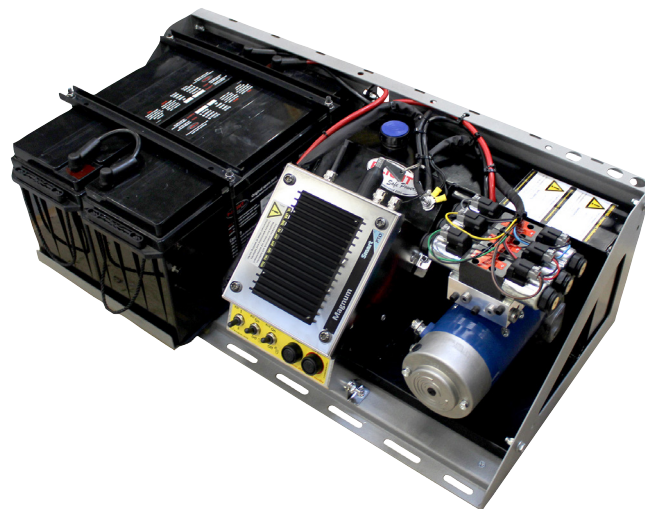

P-LIGHT Hydro is complete with powerful hydraulics adapted for trailers. Charging can be done with up to 30A and batteries up to 200Ah. Here, everything is collected on a chassis for easy installation in an existing toolbox. Available with different engine and pump options such as 2.4 kW and 4.5 kW engines and oil tanks of 13 or 22 liters.

P-LIGHT Hydro can easily be ordered with P/T or with up to valves adapted for e.g. ramps, trailer cover, bogie lift, sliding bogie, sliding sled and the most common hydraulic and pneumatic functions found on trailers, with or without radio control.

See also function overview on page 6.

Art.nr	Article
PL1812081-2-13	Hydro 880 10A/120Ah/2.4kW/13L P&T
PL1815081-2-13	Hydro 880 10A/150Ah/2.4kW/13L P&T
PL1815081-4-13	Hydro 880 10A/150Ah/4.5kW/13L P&T
PL1815083-4-13	Hydro 880 30A/150Ah/4.5kW/13L P&T
PL1820103-4-13	Hydro 1080 30A/200Ah/4.5kW/13P&T
PL1820123-4-22	Hydro 1250 30A/200Ah/4.5kW/22LP&T

P-LIGHT Hydro 880 mounting in toolbox. Dimensions: 100x50x50 cm
 P-LIGHT Hydro 1080 mounting in toolbox. Dimensions: 120x50x50 cm
 P-LIGHT Hydro 1250 mounting in toolbox. Dimensions: 135x50x50 cm

Option Hydraulic Valves

P-LIGHT Hydro Comp and P-LIGHT Hydro can be equipped with up to 3 valves, which means you can run up to 3 functions, we help with calculations and which valves should be installed.

Model
Directional valve NG4 C11 CC 27V
Directional valve NG4 H11 OC 27V
Directional valve NG4 Y11 OC 27V
Directional valve NG4 Z11 CC 27V
Sandwich Lock valve NG4 NC A-B
Sandwich Lock valve NG4 NO A-B
Sandwich Pilot controlled valve NG4 A1 & B1

OC = Open Center - CC = Close Center - NO = Normally Open - NC = Normally Close
 - P = Pressure - T = Tank - A = Port A - B = Port B

P-LIGHT Hydro Comp

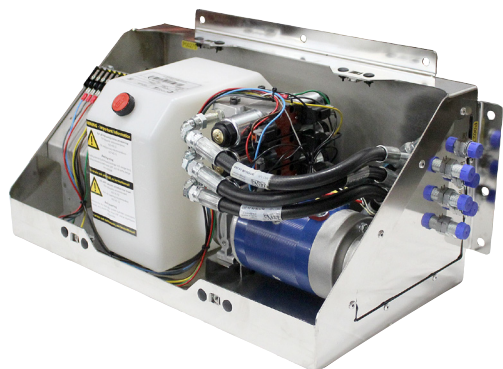

With P-LIGHT Hydro Comp you operate hydraulic equipment on trucks and trailers. It has a 2kW motor and a 7 liter tank, can be equipped with up to 3 valves. Can be combined with any P-LIGHT or powered directly by car or via NATO cable.

Art.nr	Article
PL18HC-2-LR	P-LIGHT Hydro Comp 2kW LowRoof
PL18HC-2-PT	P-LIGHT Hydro Comp 2kW P & T
PL18HC-2-1VALVE	P-LIGHT Hydro Comp 2kW - 1 Valve
PL18HC-2-2VALVE	P-LIGHT Hydro Comp 2kW - 2 Valves
PL18HC-2-3VALVE	P-LIGHT Hydro Comp 2kW - 3 Valves

P-LIGHT Hydro Pack

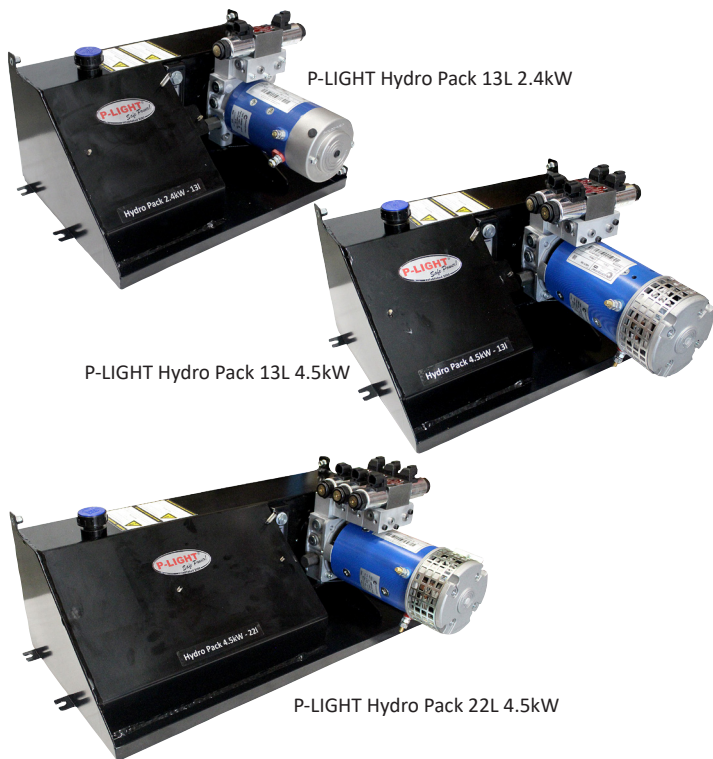

P-LIGHT Hydro Pack 13L 2.4kW

P-LIGHT Hydro Pack 13L 4.5kW

P-LIGHT Hydro Pack 22L 4.5kW

With P-LIGHT Hydro Pack you operate hydraulic equipment on trucks and trailers. It has a 2.4kW or 4.5kW motor and 13 or 22 liter tank, can be equipped with up to 3 valves. Can be combined with any P-LIGHT or powered directly by car or via NATO cable.

Art.nr	Article
PL1800000-2-13	P-LIGHT Hydro Pack 13L 2.4kW P&T KPL
PL1800000-4-13	P-LIGHT Hydro Pack 13L 4.5kW P&T KPL
PL1800000-4-22	P-LIGHT Hydro Pack 22L 4.5kW P&T KPL

P-LIGHT Radio



All P-LIGHT can be equipped with a radio. P-LIGHT Radios are programmed and adapted to our products and can be specially adapted and programmed by us to most functions needed for efficient use.

Art.nr	Article
PL190305	P-LIGHT Radio 3 buttons/5 relay Up to 3 functions - 1 table
PL190811	P-LIGHT Radio 8 buttons/11 relay Up to 7 functions - 1 board Up to 11 functions - 2 board
PL191011	P-LIGHT Radio 10 buttons/11 relay Up to 9 functions - 1 board
PL190819	P-LIGHT Radio 8 buttons/19 relay Up to 13 functions - 2 board
PL191019	P-LIGHT Radio 10 buttons/19 relay Up to 17 functions - 2 board

P-LIGHT ADR-Kit



Installation of P-LIGHT in a vehicle for the carriage of dangerous goods according to ADR /ADR99.

- The provisions of ADR/ADR 99 must be observed for the installation of P-LIGHT in vehicles for the carriage of dangerous goods.

Art.nr	Article
PL5800	P-LIGHT ADR-Kit Midi
PL5803	P-LIGHT ADR-Kit Maxi
PL5805	P-LIGHT ADR-Kit Maxi XL
PL5808	P-LIGHT ADR-Kit Magnum Frame
PL5810	P-LIGHT ADR-Kit Magnum/Hydro

Function Overview - Choose the right model for your needs.

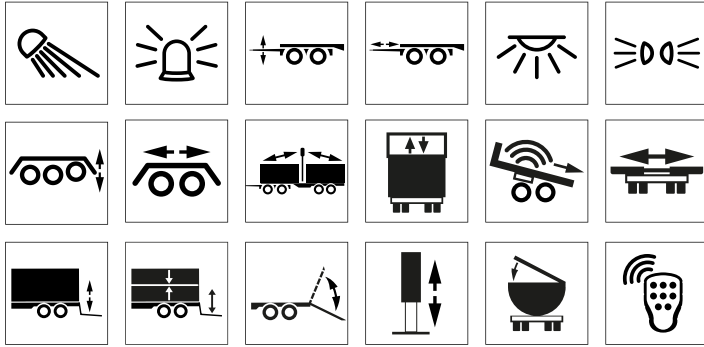

Below are examples of what each P-LIGHT model can control and operate as well as what maximum output it has and what effect it can give. Use this as a guide to find the right model for your needs.

If you need help figuring out what is needed to run the functions you need, please contact us and we will help you find the right model with the right power, charging, battery, etc.

Function ↓ (electric or hydraulic)	Model →	Midi	Maxi	Maxi XL	Maxi XL HyCover	Maxi XL Hydro Comp	Magnum Split/Frame	Hydro	Hydro Comp Hydro Pack	Magnum Frame Hydro Frame
Parking light		x	x	x	x	x	x	x	-	x
Radio/remote control		x	x	x	x	x	x	x	-	x
Strobe light		-	x	x	x	x	x	x	-	x
Courtesy light		-	x	x	-	x	x	x	-	x
Work light		-	x	x	x	x	x	x	-	x
Power Take-Off		-	-	x	x	x	x	x	-	x
Heating system		-	-	x	-	x	x	x	-	x
Electrical vibrators		-	-	x	-	-	-	-	-	-
Tail lifts		-	-	-	-	-	x	-	-	-
Trailer cover Ängsgården		-	-	-	x	-	-	-	-	-
Double floor		-	-	-	-	-	x	-	x	-
Ramps		-	-	-	-	x	-	x	x	x
Drawbar		-	x	x	x	x	x	x	-	x
Pneumatic valves		-	x	x	x	x	x	x	-	x
Hydraulic equipment		-	-	-	-	x	-	x	x	x
Electronic equipment		-	x	x	x	x	x	x	-	x
1-Axle Steering		-	-	-	-	x	-	x	x	-
2-Axle steering		-	-	-	-	-	-	-	x	x
Max simultaneous Watt outtake		50	270	270	270	270	270	270	-	270
Max outtake in Amp, Solenoid		-	-	1x<100	-	1x<100	1x<300	-	-	-
Max outtake in Amp, Relä		-	-	1x<50	-	1x<50	1x<50	-	-	-
Hydraulic motor Power kW		-	-	-	-	2	-	2,4/4,5	2/2,4/4,5	3
Battery capacity Ah*		18	45	45	45	45	120-200	120-200	-	150
Charging A**		5	10	10 (20)	10	10 (20)	10 (30/45)	10 (30)	-	10 (45)
Volt		24	24	24	24	24	24	24	-	24

*For Magnum, Magnum Split, Magnum Frame and Hydro you may choose 120Ah, 150Ah or 200Ah batteries.

** The value in brackets is what can be ordered as an option, a total of 20A or 30A. 45A charging applies only to Magnum Frame.

P-LIGHT - Dimensions and Weights

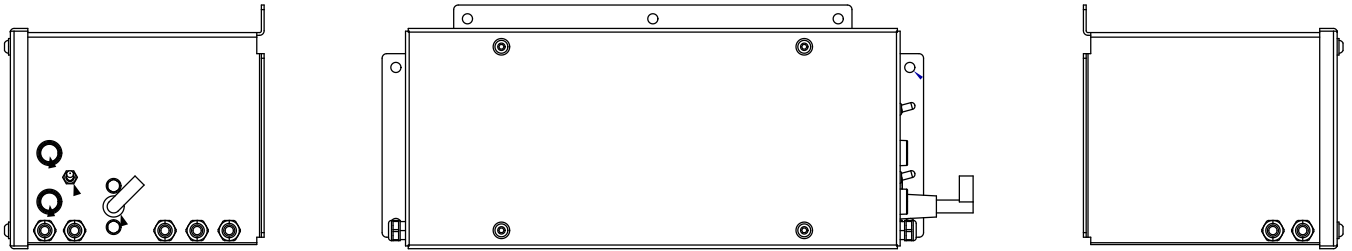

P-LIGHT Model	Battery/Engine Ah/kW	Length mm		Width mm	Height mm		Weight about kg
		without bracket	with bracket		without bracket	with bracket	
P-LIGHT Midi	18Ah	210	260	240	190	210	20
P-LIGHT Maxi	45Ah	430	490	250	230	260	45
P-LIGHT Maxi XL	45Ah	530	590	280	230	260	50
P-LIGHT Hydro Comp 7L	-/2kW	590	630	330	272	295	20
P-LIGHT Magnum 680	120Ah	680	440			290	100
P-LIGHT Magnum 680	150Ah	680	480			290	120
P-LIGHT Magnum 880	150Ah	880	440			290	125
P-LIGHT Magnum 880	200Ah	880	480			290	160
P-LIGHT Magnum Split	exkl. batterier		215	330		145	10
P-LIGHT Magnum Frame 435	120/150ah	690	809	495		306	125/150
P-LIGHT Magnum Frame 567	200Ah	690	809	626		306	200
P-LIGHT Hydro 880	120Ah		880	440		290	130
P-LIGHT Hydro 880	150Ah/2,4kW		880	478		290	150
P-LIGHT Hydro 1080	150Ah/4,5kW		880	478		290	160
P-LIGHT Hydro 1080	200Ah/2,4kW		1080	478		290	170
P-LIGHT Hydro 1080	200Ah/4,5kW		1080	478		290	175
P-LIGHT Hydro 1250	200Ah/4,5kW		1250	481		292	180
P-LIGHT Hydro Comp m tank	-/2kW	590	630	375	240	260	50
P-LIGHT Hydro Pack 13L	-/2,4kW		499	393		248	25
P-LIGHT Hydro Pack 13L	-/4,5kW		499	464		248	35
P-LIGHT Hydro Pack 22L	-/4,5kW		699	464		248	40
P-LIGHT Batteries	Capacity Ah	Length mm		Width mm	Height mm		Weight kg
PL2170 P-LIGHT Battery	18Ah	180		75	165		6,5
PL2450 P-LIGHT Battery	45Ah	197		165	171		15
PL 2512 P-LIGHT Battery	120Ah	410		176	227		38
PL2515 P-LIGHT Battery	150Ah	485		172	240		47
PL2520 P-LIGHT Battery	200Ah	522		238	223		65

P-LIGHT Tail Lamp Cleaner™

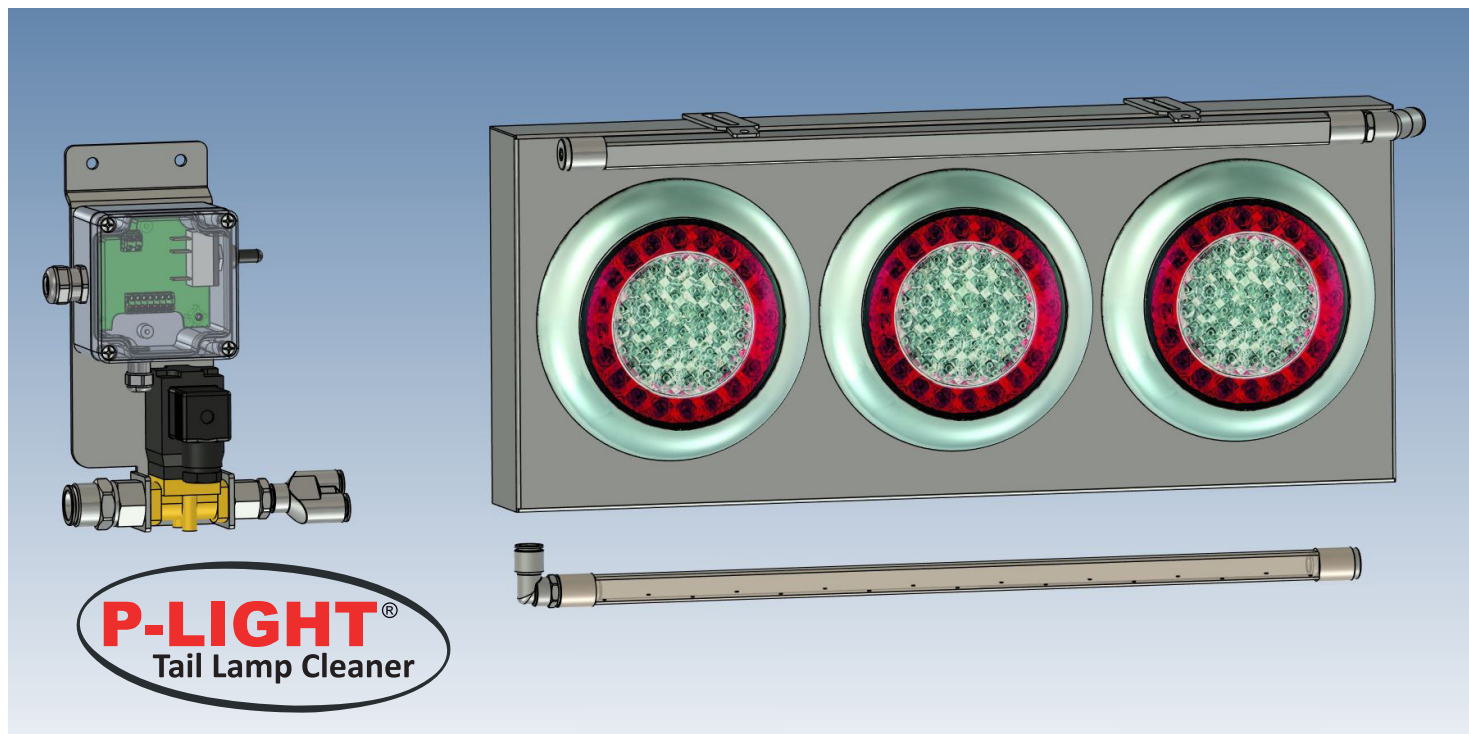

Increase visibility and Save lives, P-LIGHT Tail Lamp Cleaner keeps tail lights free of snow.

Snow on wintry roads can quickly form an impenetrable white blanket over the rear lights of heavy vehicles and make them difficult to spot in traffic.

This annually causes rear-end collisions and can also result in a fine at a police check.

The P-LIGHT Tail Lamp Cleaner is an accessory that eliminates the problem in a simple and effective way. Mounted immediately above the rear lights, blows the snow away before it has time to stick and cover the lighting.

The P-LIGHT Tail Lamp Cleaner is easy to assemble and does not require major interventions. The equipment consists of nozzle pipes with a control unit that is connected to the trucks air system. The control unit is controlled manually with buttons or via radio/remote control which activates compressed air through small holes in the nozzle pipes and blows the tail lights clear of snow. A built-in safety system ensures that the vehicle's other functions are not affected.

P-LIGHT Tail Lamp Cleaner is EMC approved according to Reglemente 10, the regulatory framework that ensures the protection requirements for electrical equipment, systems and installations on vehicles.

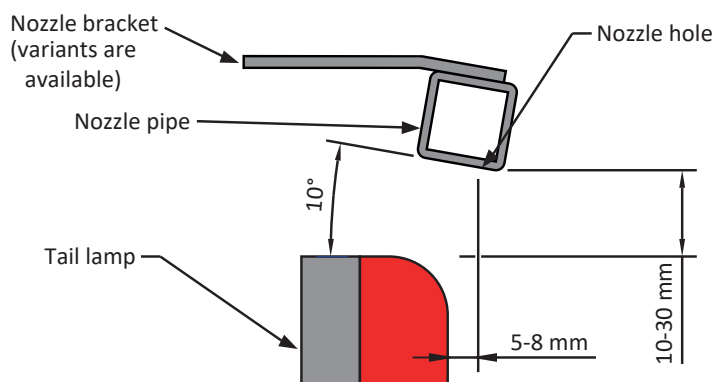

Art No.	Article
TLC10C1HL-24-450-KPL	P-LIGHT Tail Lamp Cleaner



P-LIGHT is a registered trademark owned by InnoNet AB

InnoNet AB
Olvägen 7
SE-342 50 Vislanda
Phone +46 472 483 83
Support +46 472 483 93
www.innonet.se
www.p-light.com

Dealer/Workshop/Bodybuilder

P-LIGHT - Contact

Technical sales

Phone: +46 472-483 89

E-mail: sales@innonet.se

Support

Phone +46 472-483 93

E-mail: support@innonet.se

Order

Phone +46 472-483 83

E-mail: order@innonet.se

See our website - support.p-light.com - for support and technical information.